

Year 5: Computing – Programming (Selection in physical Computing)

Overview

Selection in Physical Computing

- Programming is when we make and input a set of instructions for computers to follow.
- Microcontrollers are devices that can be programmed to control output devices that are connected to them.
- We use algorithms which we can plan, model, trial and debug, in order to create accurate command sequences, involving multiple output devices (e.g. LEDs and motors).

What is a Micro:bit?

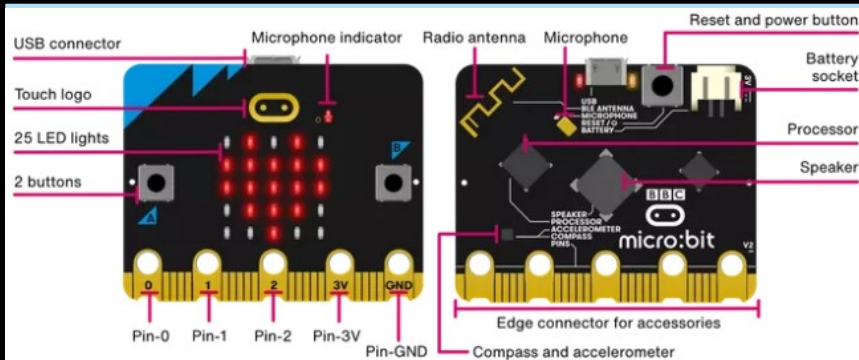

A Micro:bit is a type of microcontroller—a small device that can be programmed to control devices connected to it. It can hold one algorithm on it, which can turn it into a magic 8-ball (answering questions), a thermometer (measuring temperature), a gyroscope (measuring tilt), a step-tracker, and many other things.

KEY VOCABULARY:



Programming: Creating a set of instructions for a computer to follow.



Circuit: a complete path that electricity can flow around.



Electricity: The net flow of electrons around a circuit.



Microcontroller: A microcontroller is a small device that can be programmed to control devices that are connected to it. A Micro:bit is a brand of microcontroller.



Code: A set of instructions in a programming language that can be followed by a computer.



LED: Light Emitting Diodes are output devices that give out light when electricity is passed through them.



Algorithm: A set of step-by-step instructions that describe how to perform a



Modify: To change the value of a piece of information



Debugging: Problems in a code are called 'bugs'. Debugging is the process of removing errors from a code.

Sequencing and Algorithms

-A **sequence** is a pattern or process in which one thing follows another.

-We design **algorithms** (sets of instructions for performing a task) to help us program sequences involving multiple output devices (e.g. LEDs and motors).

-**Programming** is the process of keying in the code recognized by the computer into the software (using your algorithm).

```

forever
  if button A is pressed
    then set motor 1 to forwards at 50%
    set Sparkle 0 to green
    set Sparkle 1 to red
    pause 1 second
    set Sparkle 0 to red
    set Sparkle 1 to green
    pause 1 second
    
```

Trialling and Debugging

-Programmers do not put their computer programs straight to work. They **trial** them first to find any errors:



-**Sequence errors:** An instruction in the sequence is wrong or in the wrong place.

-**Keying errors:** Typing in the wrong code.

-**Logical errors:** Mistakes in plan/thinking.

-If your algorithm does not work correctly the first time, remember to **debug** it.